

SPEAKMAN COMPANY

SC-7120 thru SC-7129 Series Installation, Maintenance & Operation

Instructions

DOUBLE LABORATORY FAUCET

DESCRIPTION

Speakman polished chrome plated double laboratory faucet with ¼ turn ceramic valves. Brass body. 5-1/4 spread brass gooseneck, swivel or rigid. Metal handles with color coded indexes. Vandal-resistant water conserving aerated outlet device reduces flow to 2.2 GPM/8.4 LPM maximum to meet existing ASME A112.18.1/CSA B125.1 Standard. ½”-14 NPSM male threaded flexible copper inlets.

SPECIFICATIONS

SUPPLY: ½-14 NPSM COMPRESSION COUPLING.

FLOW RATE: 2.2 GPM/8.4 LPM MAX.

SHIPPING WEIGHT: 4.4 LBS (SC-7122)

OPTIONS

◇ BOCA - Vandal-Resistant 0.5 gpm Flow Control Device	◇ ST- Serrated Tip (Vacuum Breaker Spout Only)	◇ GB - Vandal-Resistant 1.5 GPM Aerator Outlet Device
◇ FC - Laminar Flow Plain End Spout (2.0 gpm)	◇ SW – Swivel Spout Assembly (Vacuum Breaker Spout Only)	◇ 8 - 8” Spread Gooseneck Spout
◇ LF - Vandal-Resistant 2.2 gpm Laminar Flow Control Device	◇ VB6 - 6” Spread Rigid Vacuum Breaker Spout	◇ 9 - 9” Swing Spout
◇ MI – Metal Indexes	◇ VB8 - 8” Spread Rigid Vacuum Breaker Spout	◇ 12 – 12 Swing Spout
◇ SO – Spray Outlet	◇ 4 - 3-3/4” Spread Gooseneck Spout	◇

INSTALLATION INSTRUCTIONS

- 1) If applicable, install the anti-rotation pin into body hole and drill hole in sink/countertop (See separate instruction/template sheet located in the hardware bag group).

Note- (Rigid vacuum breaker spouts only) If space is limited between faucet hole and backsplash/wall, install rigid vacuum breaker spout to faucet body at this time (See Step #5).

- 2) Thread the plain end of the mounting studs (2) into the underside of the valve body and tighten with a Phillip screwdriver. With the copper inlet tubes (2) squeezed together by hand, install the rubber friction/seal gasket over inlet tubes and mounting studs. Make sure gasket cut outs (2) are positioned over/around mounting studs.
- 3) Again with the tubes squeezed together, carefully place faucet in hole (1-1/4 diameter minimum) of sink/countertop, with the mounting studs towards the back, making sure the gasket is still positioned properly. Working from under the sink, slip the rubber gasket, than the brass hold down washer onto the mounting studs. Make sure the washers (2) open side is facing forward for clearance of the inlet tubes. Screw the hold down nuts (2) onto the mounting studs and hand tighten. With the faucet positioned properly, wrench tighten nuts, using a small adjustable or ½ open-end wrench.
- 4) Carefully spread inlet tubes slightly apart. Hand tighten water supply lines (2) to the inlet tubes. **IMPORTANT- When tightening supply lines to the inlet tubes, hold the inlet tube fittings (2) with a adjustable or 11/16 open-end wrench. Make sure not to twist or damage the inlet tubes.** Wrench tighten supply line connections.
- 5) From above sink, remove plastic plug from body outlet. **For All Swiveling Spouts:** Remove lock washer from body outlet. Install spout assembly and wrench tighten spout collar nut. **For Rigid Spouts:** With the lock washer in place, install the spout assembly, position, and wrench tighten the spout collar nut. **For Rigid Vacuum Breaker Spouts:** Remove lock washer from body outlet. **IMPORTANT- Install rigid adapter in body and wrench tighten** (See Rough-In on back side of sheet). Apply thread locker/sealant to the spout tapered pipe threads. Screw the spout into the adapter until the threads start to get snug. **Note-** When positioning the spout, hold adapter hex with a wrench, so body does not rotate. Holding the hex of the adapter with a wrench, tighten the spout at least 1/3 turn to the proper position (Do not over tighten spout). Remember that the thread locker/sealant will lock and seal the spout assembly in place.
- 6) Slip trim sleeves (2) onto valve spindles (2). Position handles (2) and screw onto spindles. Press index buttons (2) into handles.
- 7) Turn water supplies (2) on and flush out both sides of faucet. Install outlet device (If applicable) and check all connections for leaks.

OPERATION

Simply rotate the handles ¼ turn maximum to operate the laboratory faucet.

MAINTENANCE (CARE and CLEANING)

The faucet valves are washerless and requires no routine maintenance. The gleaming finish of your SPEAKMAN laboratory faucet can be cleaned by using mild soap and warm water. Dry immediately with a soft, clean cloth for best results.

ROUGH-IN MEASUREMENTS

(Model SC-7122 shown)

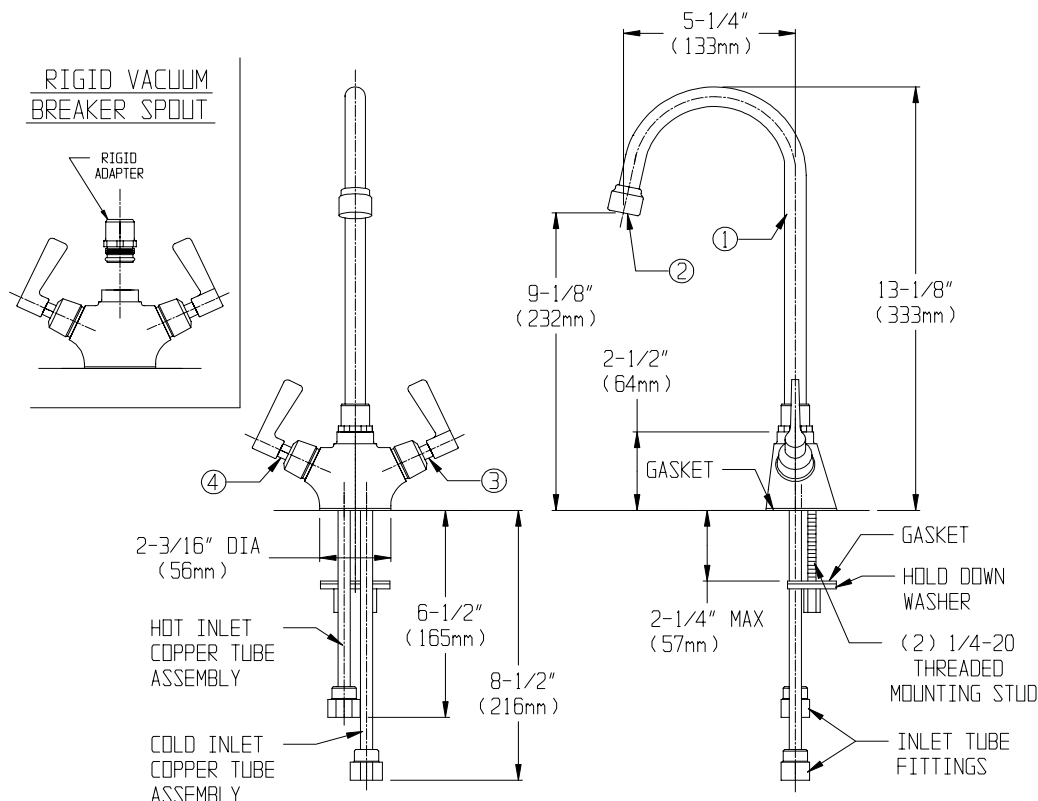

NOTES:

- 1) ALL DIMENSIONS ARE IN INCHES (mm) UNLESS OTHERWISE SPECIFIED AND ARE SUBJECT TO CHANGE WITHOUT NOTICE.
- 2) INLETS ARE SIZED FOR EITHER COUPLING OR SWEAT CONNECTIONS.

REPAIR / REPLACEMENT PARTS

<u>ITEM NUMBER</u>	<u>PART OR GROUP NUMBER</u>	<u>DESCRIPTION</u>
1	RPG18-0213-PC	STANDARD 5" SPREAD GOOSENECK ASSEMBLY
2	RPG05-0674-PC	2.2 GPM AERATOR ASSEMBLY
3	RPG05-0532	PERFECT® VALVE GROUP (RED) W/TRIM SLEEVE AND SCREW
4	RPG05-0533	PERFECT® VALVE GROUP (BLUE) W/TRIM SLEEVE AND SCREW

SPEAKMAN®

PO Box 191 Wilmington, DE 19899 Phone: 800-537-2107 Fax: 800-977-2747
Visit us on the web at www.speakmancompany.com