

# SPEAKMAN SAFETY PRODUCTS

## Installation, Maintenance & Operation Instructions

### SEF-1800-SL EYESAVER® FAUCET

#### DESCRIPTION

The SEF-1800 Eyesaver® faucet combines a gooseneck faucet with an independently operated eyewash. The faucet features a vandal resistant, single lever faucet utilizing a ceramic cartridge with an adjustable temperature limit and flow control.

#### SPECIFICATIONS

**OPERATION:** Eyewash and faucet operate independently of each other

**SUPPLY:** 3/8 compression male connections for hot and cold inlets

**FAUCET VALVE:** Ceramic cartridges

**FINISH:** Chrome plated brass

**EYEWASH ACTIVATION:** Pull handle with graphics

**EYEWASH SPRAYS:** Aerated sprays.

**FAUCET FLOW RATE:** Autoflo® device controls flow to 2.2 GPM/ 8.3 LPM

**EYEWASH FLOW RATE:** 2.6 GPM at 30 psi. flowing. See flow data chart for additional information.

**PRESSURE:** 30 psi. minimum flow pressure, 80 psi. maximum static pressure

**APPROVALS:** Meets ASME A112.18.1, ANSI Z358.1 and CSA B125-98

**VACUUM BREAKER (ST option):** Approved by ASSE, UPC and CSA. Meets the ANSI/ASSE 1035 standard for "Laboratory Faucet Vacuum Breakers", CSA B64.8 and UPC.

**SHIPPING WEIGHT:** 10 LBS.

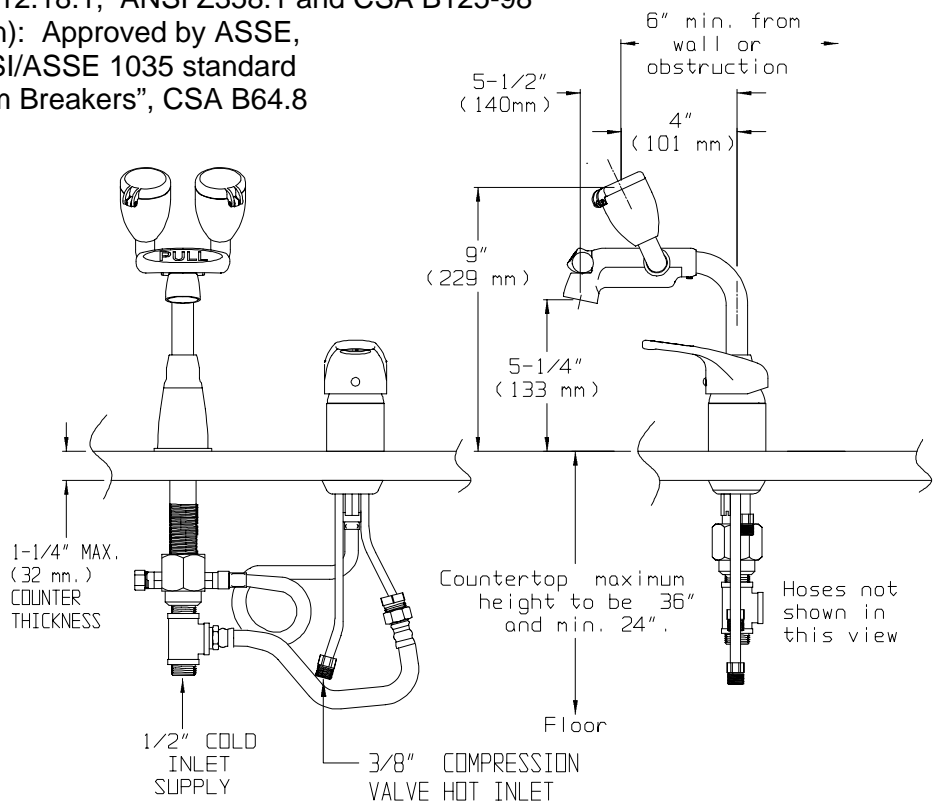

**Notes:**  
All dimensions are in inches (millimeters) unless otherwise specified and are subject to change.

**IMPORTANT:** The supply line for plumbed units shall provide an uninterrupted supply of flushing fluid at a minimum of 30 psi. of flow pressure. If shut off valve are installed in the supply line of the eyewash for maintenance purposes, provisions shall be made to prevent unauthorized shut off.

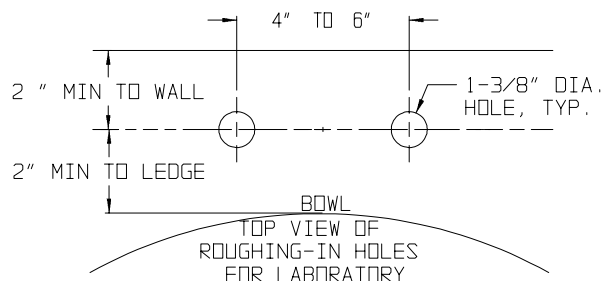

12/05 rev.4  
92-2512

**OPTIONS**

◇ BOCA – Vandal-Resistant 0.5 gpm Flow Control
◇ LF – Laminar Flow Outlet 2.2gpm
◇ ST – Serrated Tip with Vacuum Breaker

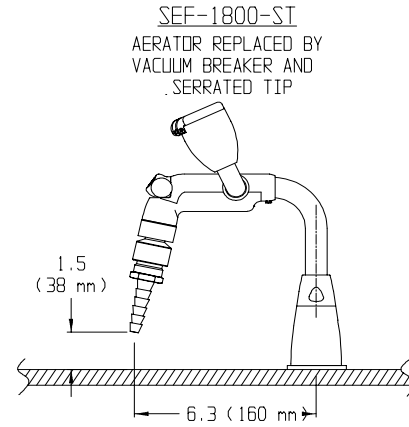

**FLOW DATA**

Flowing Pressure- psi. (BAR)	30 (2.07)	40 (2.76)	50 (3.45)	60 (4.14)	70 (4.83)	80 (5.52)
Flow Rate- gpm (LPM)	2.6 (9.8)	2.9 (11)	3.0 (11.4)	2.8 (10.6)	2.8 (10.6)	3.0 (11.4)
Distance Eyewash Plume, 'A' - ins. (cm.)	13 (33.0)	14-1/2 (36.8)	15 (38.1)	15 (38.1)	15 (38.1)	16 (40.6)

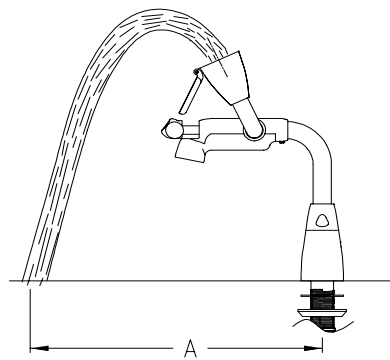

12/05 rev.4  
92-2512

**PACKING LIST**

Item	Description	Qty.	Item	Description	Qty.
1	Single lever Valve	1	7	½ to 3/8 Hose	1
2	Valve Mounting Hardware Bag Group	1	8	Aerator	1
3	Gooseneck Eyewash	1	9	Serrated Tip and Vacuum Breaker for -ST option, (replaces item #8)	1
4	Gooseneck Mounting Hardware	1	10	.5 gpm aerator for - BOCA option, Item not shown (replaces item #8)	1
5	3/8 Hose	1	11	Laminar flow outlet for - LF option, Item not shown (replaces item #8)	1
6	Tee Assembly	1			

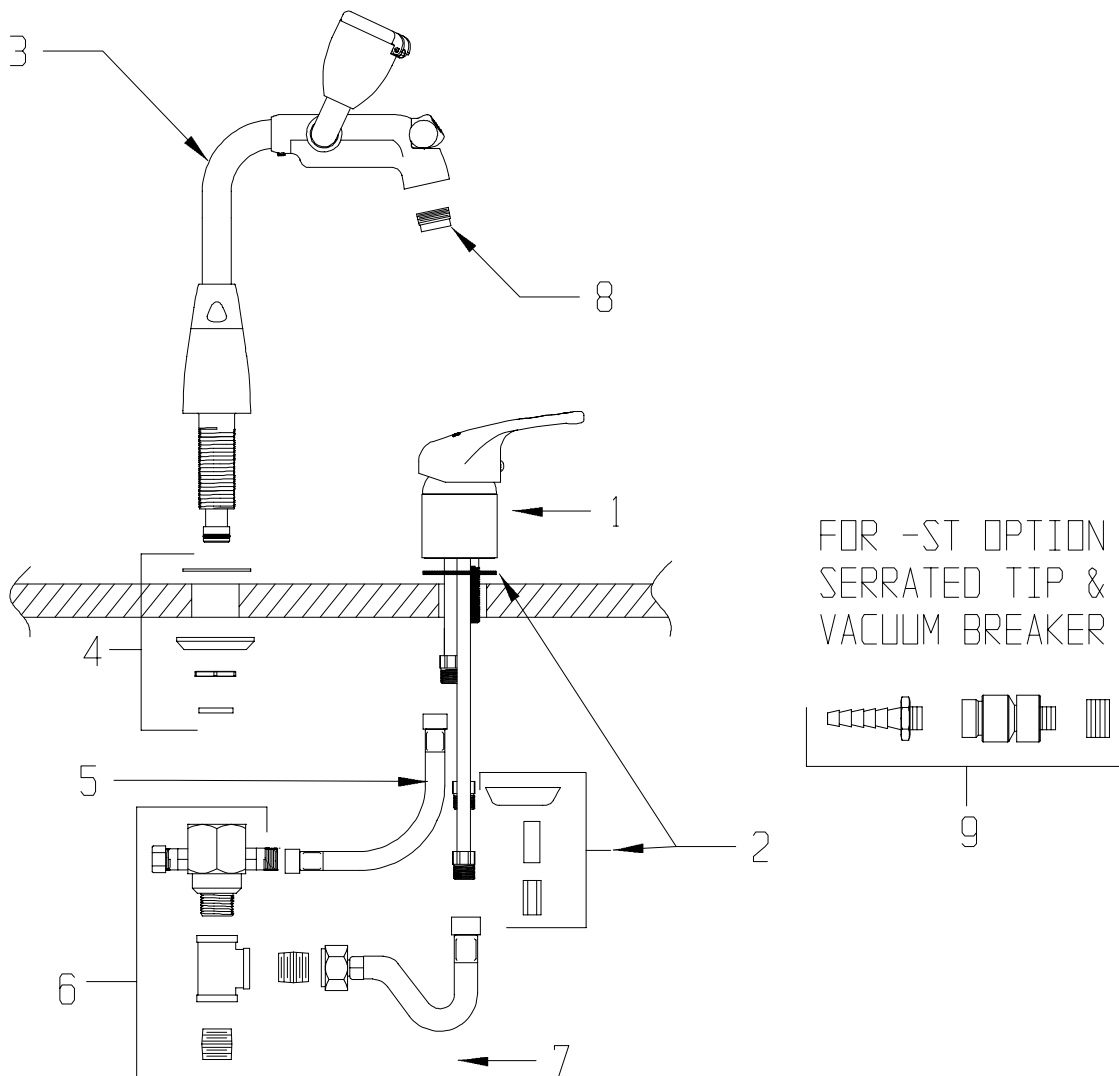

FOR -ST OPTION  
SERRATED TIP &  
VACUUM BREAKER

## INSTALLATION

### Step 1: Gooseneck Eyewash Mounting-

- Place the gasket and deck plate onto the sink bowl. Slip the base washer onto the gooseneck eyewash and slip through the center hole of the sink or countertop.
- The gooseneck eyewash swivels through 200° of rotation. Position the base of the gooseneck eyewash so the setscrew hole in the base is pointing towards the back of the sink or countertop. Note- For rigid gooseneck, position the gooseneck and tighten the setscrew in the mounting base. From below the sink slip the cup washer onto the shank and use the nut to tighten the assembly down onto the sink or countertop.
- Important-** Next insert the rubber seal into the adapter and screw the adapter onto the shank of the gooseneck eyewash until it bottoms out (Tape may be applied to the shank). If the adapter needs to be positioned for hose attachment, it can be backed off up to a maximum of 1 / 2 turn.
- Apply tape or sealant and connect the tee and nipples so that the tee outlets are accessible.

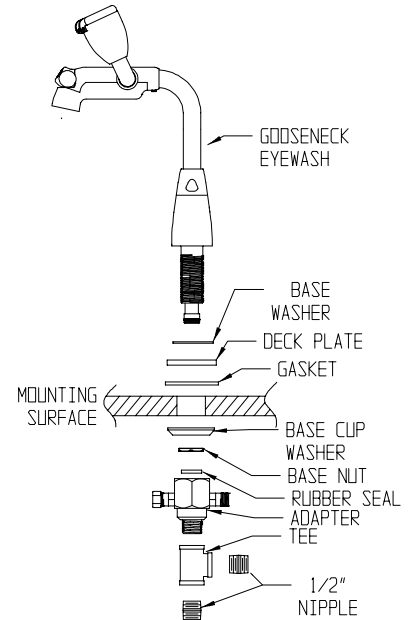

### Step 2: Valve Assembly-

- Slide the gasket up over the tubes.
- Slip the tubes through the hole in the sink. Make sure the gasket is properly aligned in the cavity of the valve sleeve.
- Secure the valve using the mounting bracket and tighten using the wrench provided. Use the spacer washer for thin sink applications.

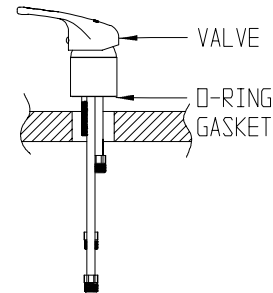

### Step 3: Hose Connections-

- Warning: Be careful when bending the copper tubing. Kinked tubes will void the warranty. Use a wrench to hold the soldered connectors, do not twist these. While the soldered connectors are secure, tighten the hose connection with the other wrench. DO not over tighten.
- Screw 3/8" hoses onto the side outlet of the valve outlet (Shortest length tube) and tighten. Screw the other end of the hose onto base adapter.
- Connect male end of the 1/2" hose to the side port of the tee as shown. Attach the other end to the valve cold side inlet (Middle length tube) and tighten.
- Connect the vertical inlet of the tee to the cold water inlet supply.
- Connect the hot water supply line to the inlet of the hot water valve body (Longest length tube) and tighten the coupling nut. **Note- Use a flexible hose connection for the hot water supply. Use of copper tube supply connections may interfere with function of checks located in the inlets.**

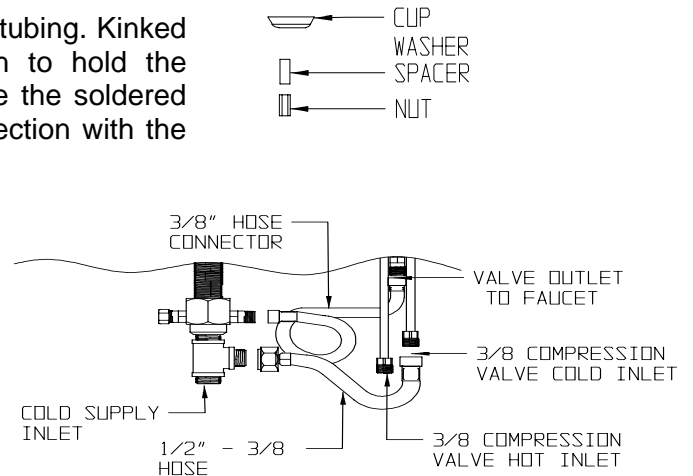

12/05 rev.4  
92-2512

**Step 4: Unit Flushing-**

- After the assembly is complete, turn the hot and cold water supplies on and check for leaks.
- Activate the faucet to flush both the hot and cold sides of fixture. Check all connections for leaks.
- Install the aerator into the faucet outlet.
- At this time activate faucet and then activate the eyewash by pulling the handle and assure proper spray formation and no leaks.

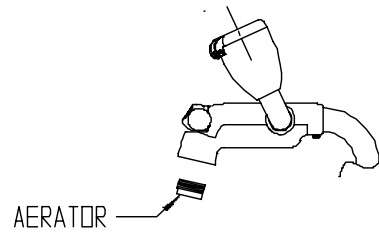

TEMPERATURE LIMIT STOP RING ADJUSTMENT

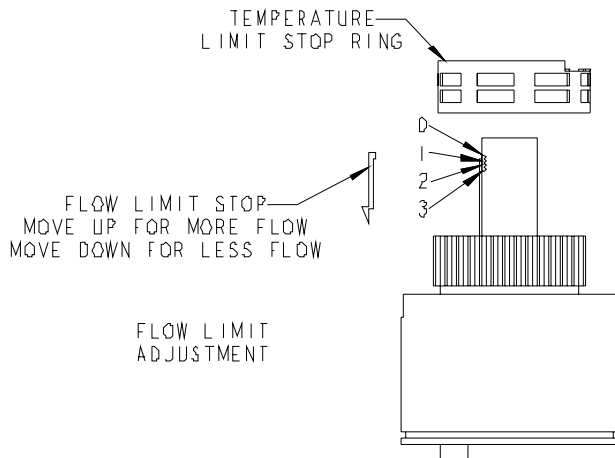
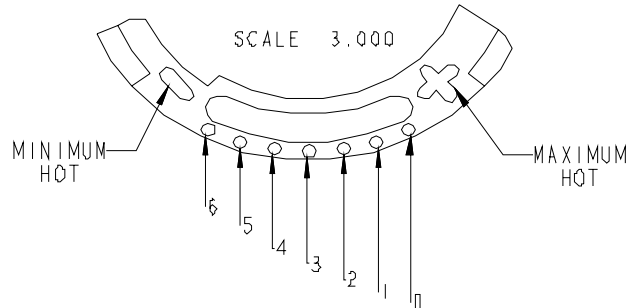
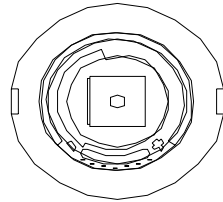

POSITIO N @ 45 PSI.	FLOW LIMIT	TEMP. L IMIT
0	0%	0%
1	5%	0%
2	12%	3%
3	25%	10%
4		20%
5		30%
6		40%

**FLOW AND TEMPERATURE ADJUSTMENT INSTRUCTIONS**

*Adjusting Temperature Limit:*

- Remove handle by removing red/blue button (2) and set screw (3) using an Allen key and remove collar (4) by hand counter-clockwise.
- With cartridge control shaft in the center and off position, carefully lift and rotate the temperature limit stop ring to the desired setting using needle nose pliers or by hand. Clockwise rotation of the ring increases temperature and counterclockwise rotation of the ring lowers temperature (see table and schematic for details). Turn water on and test for desired temperature.

*Adjusting Flow Limit control:*

- Using a thin flat screwdriver, carefully remove flow limit stop by prying it away from the cartridge control shaft.
- Reset flow limit stop higher on the shaft to increase flow or lower to decrease flow.
- Re-install handle and check for proper operation.

NOTE: The flow limit adjustment is effective when a higher than 2.2 GPM flow outlet is installed in the faucet or the flow outlet has been removed.

12/05 rev.4  
92-2512

**ALTERNATE INSTALLATION FOR DEDICATED TEPID WATER SUPPLY**

The unit is designed so the eyewash has a dedicated supply line. This allows the eyewash to have a tepid water supply. For this type of installation, follow the installation instructions but do not assemble the tee, nipple and 1/2" hose (Steps 2d, 3b and 3c). Attach the tepid water supply to the center adapter as shown in the figure and your cold water supply to the cold valve body.

ANSI Z358.1-1998 requires that the delivered flushing fluid temperature shall be tepid. Also, in circumstances where chemical reaction is accelerated by flushing fluid temperature, a medical advisor should be consulted for the optimum temperature of each application.

**IMPORTANT:** The supply line for plumbed eyewash units shall provide an uninterrupted supply of flushing fluid at a minimum of 30 psi. of flow pressure. If shut off valve is installed in the supplyline of the eyewash for maintenance purposes, provisions shall be made to prevent unauthorized shut off.

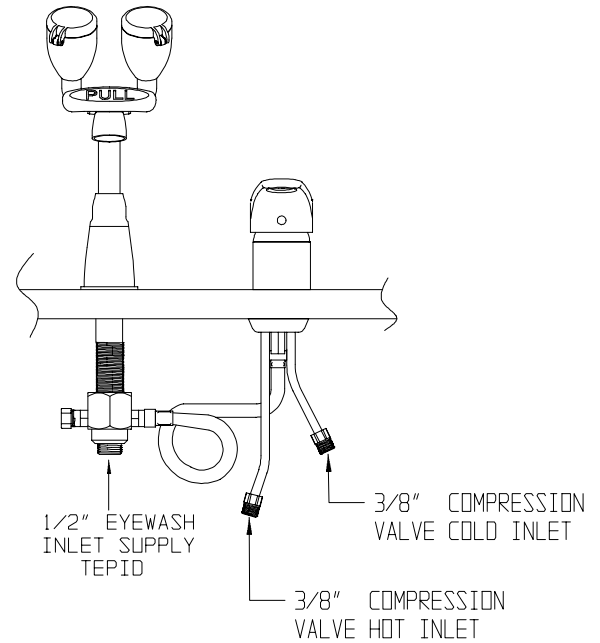

**OPERATION**

Faucet- Lift the lever to activate the faucet. To achieve the desired temperature, rotate the lever. Eyewash- The eyewash is activated by pulling the handle out. Once the eyewash is activated, the eyewash caps will flip off and water will come out of the aerated spray heads. The eyewash will continually discharge water until the handle is manually pushed back into the off position. The flow of the individual spray heads is controlled by built-in flow controls. Each spray assembly is tested and aligned in the factory.

**TESTING PROGRAM**

ANSI Z358.1 requires that all emergency equipment shall be tested weekly to verify proper operation and inspected annually to assure conformance with ANSI Z358.1 - 1998 requirement.

**MAINTENANCE (CARE and CLEANING)**

Valves are washer-less and require no routine maintenance. The gleaming finish of your SPEAKMAN Eyesaver® faucet can be cleaned by using mild soap and warm water. Rinse thoroughly and dry immediately with a soft, clean cloth for best results.

**REPAIR PARTS LISTING**

Part or Group Number	Description	Refer to Packing List Figure
G20-1979	Single Lever Faucet	
RPG38-0388	Yellow spray head and aerator repair parts assembly	Part of item 3
RPG49-0003	Repair parts for internal seals of the gooseneck eyewash	Not shown
G05-0724-PC	Faucet 2.2 gpm aerator	Item 8
RPG04-0366	Eyewash handle with yellow text and set screw	Part of item 3

12/05 rev.4  
92-2512

# SPEAKMAN SAFETY PRODUCTS

## Replacement Instructions for seals on the SEF-1800 EYESAVER® FAUCET

To service the seals for your SEF-1800, determine the issue to be addressed. The figure below shows different areas and indicates which seal to replace if needed. **Shut off water supply** before beginning any work on the SEF-1800 unit.

Area	Eyewash Valve	Faucet Valve	Replace Seals	Disassembly Instructions
A	Off	Off	2c, 4	Follow Step 3 for seal 2c. Follow Step 4 for seal 4.
A	On	Off	2b	Follow Step 1
B	On	Off	2a	Follow Step 1 & Step 2
C	Off	On	2b	Follow Step 1
C	Off	Off	1	Follow Step 1
D	Off	On	3a	Follow Step 1
E	Off	On	3b	Follow Step 3
F	Off	On	5	Follow Step 3
G	Off	On	6	Follow Step 4

### Disassembly Instructions:

Step 1- While holding the body, back off the nut slightly and then unscrew the body all the way off. Replace the necessary seals. To reassemble, screw the body back on the tube until it cannot be screwed on any further. At this point, back off the body to position the spray heads vertical, then tighten the nut onto the body securing it in place.

Step 2- To gain access to seal 2a, while the body is disassembled from Step 1, pull the handle out. This will expose a setscrew on the bottom. Remove the setscrew and push the spindle out. Replace the necessary o-ring. Put the spindle back in the body and attach the handle with the setscrew.

Step 3- Take the setscrew out of the back of the base. Unscrew the swivel nut and pull the tube out to get access to the seals. Replace the necessary seals. To reassemble, place the tube back into the base and screw down the swivel nut. Screw the setscrew into the back of the base. Do not tighten the setscrew. The tube should freely rotate.

Step 4- Disconnect any hoses to the tee. Unscrew the tee and replace any necessary seals. Screw the tee back on tight and connect the hoses.

After reassembly of the unit, with the valve in the off position, turn the water service back on and check for leaks. Verify proper operation of the eyewash and faucet.

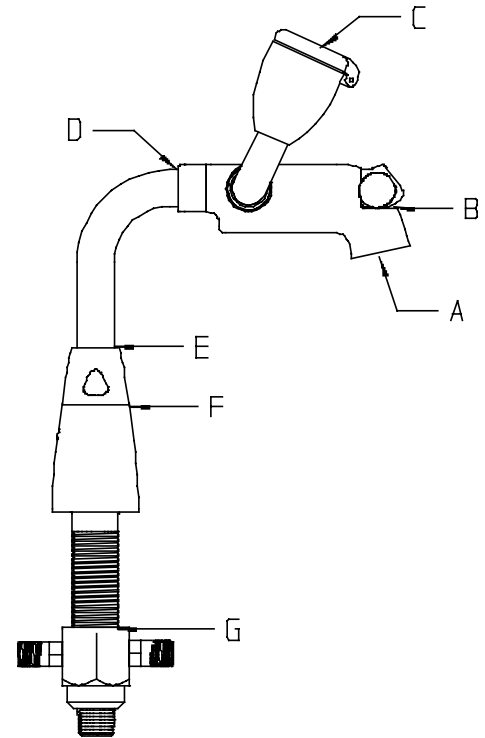

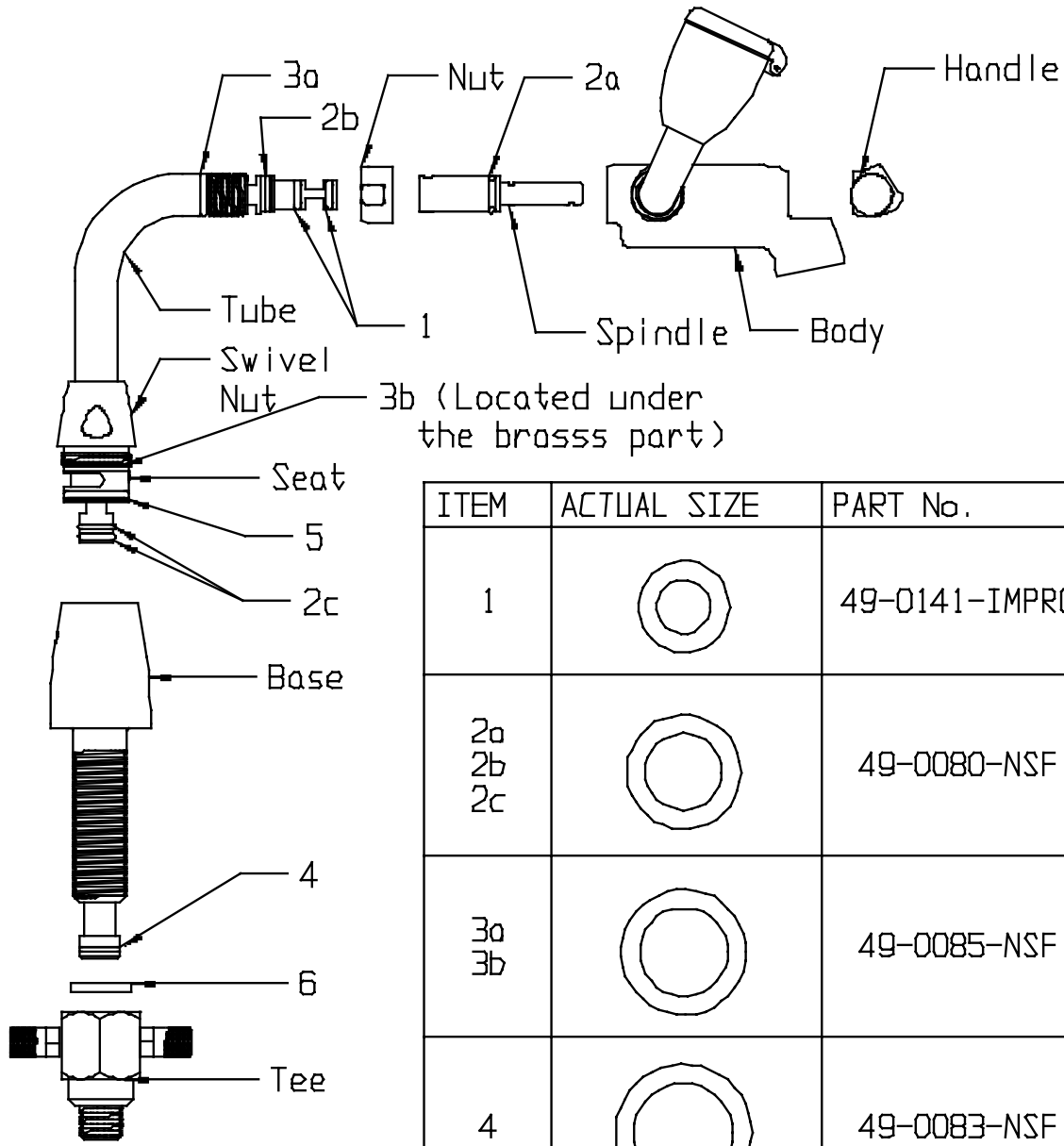

ITEM	ACTUAL SIZE	PART No.	QTY.
1		49-0141-IMPRG	2
2a 2b 2c		49-0080-NSF	4
3a 3b		49-0085-NSF	2
4		49-0083-NSF	1
5		49-0157--NSF	1
6		45-0736	1