

SPEAKMAN®

SEF-400

EYESAVER® EYE/FACE WASH

DESCRIPTION

The SE-400 Eyesaver® eye/face wash provides six aerated sprays for gentle yet thorough rinsing of the eyes and face and features a large rectangular stainless steel bowl, stay open ball valve and an in-line strainer.



SPECIFICATIONS

Bowl: 300 series stainless steel or yellow ABS plastic

Spray Heads: (6) brass, chrome-plated aerated

Valve: 1/2" NPT female brass, chrome-plated

Activator: Stainless steel push handle

Shrouds: Yellow Polypropylene

Inlet: 1/2" NPT female

Strainer: Brass, chrome-plated, in-line

Performance: 9.6 gpm @ 30 psi

Compliance: ANSI Z358.1

Universal Emergency Sign Included

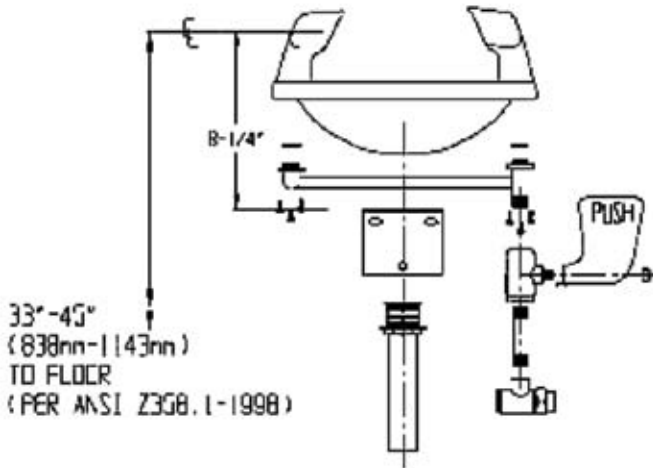

OPTIONS

- FLW Flow switch
- FPV Freeze protection valve
- HFO Hand/Foot operation
- HS Hand-held spray
- PT P-trap
- SPV Scald protection valve
- SSBV Stainless steel ball valve

Job Name _____	
Location _____	
Architect/Engineer _____	
Sales Representative _____	
Wholesaler _____	
Date _____	Model # _____