

SPEAKMAN®

SE-6400-C1D2 Combination Shower & Eye/Face Wash

DESCRIPTION

SE-6400-C1D2 Freeze protected combination shower and eye/face wash units are wrapped with heat trace cable and insulation and are jacketed in PVC to protect them to -50°F . Eye/Face wash features dual aerated spray outlets with automatic flow controls and flip top dust covers. The impellar action shower is activated by a high visibility yellow pull rod.

SPECIFICATIONS

SHOWER HEAD: 8" Dia. CYCOLAC® Yellow Plastic.

FLOW CONTROL: Internal 20 gpm Regulator.

VALVE: 1" NPTF Brass, Chrome-Plated. Full Flow Stay-Open Ball Valve.

ACTIVATOR: Powder Coated Yellow, Aluminum Triangular Pull Rod.

INTERNAL STANCHION: 1" IPS Galvanized Steel Pipe.

INLET: Through The Wall, Horizontal Top Supply

FINISH: DuraJade™ Painted Green Finish.

EYE/FACE WASH

SPRAY HEADS: (2) Yellow ABS Plastic Spray Outlets with flip-top dust caps.

VALVE: 1/2" NPTF Brass, Chrome-Plated. Full Flow Stay-Open Ball Valve.

ACTIVATOR: Stainless Steel Push Handle.

ELECTRIC

HEATING TAPE: Self-limiting parallel resistance cable with braided metal shield.

THERMOSTAT: Preset, hermetically sealed single pole contact switch. Temperature range 60° to 70°F .

INSULATION: Closed cell rubber foam.

PILOT LIGHT: .025 watt red light with push test button.

Lights when thermostat closes and heating tape is activated.

JUNCTION BOX: NEMA 4X water tight, dust tight and corrosion resistant for indoor or outdoor locations.

POWER SUPPLY: 120 vac, 60 cycle, single phase

ELECTRICAL CLASSIFICATION: Class 1 Division 2 Group B, C, D

GROUND FAULT PROTECTION: Installation will require minimum 30 mA GFPD.

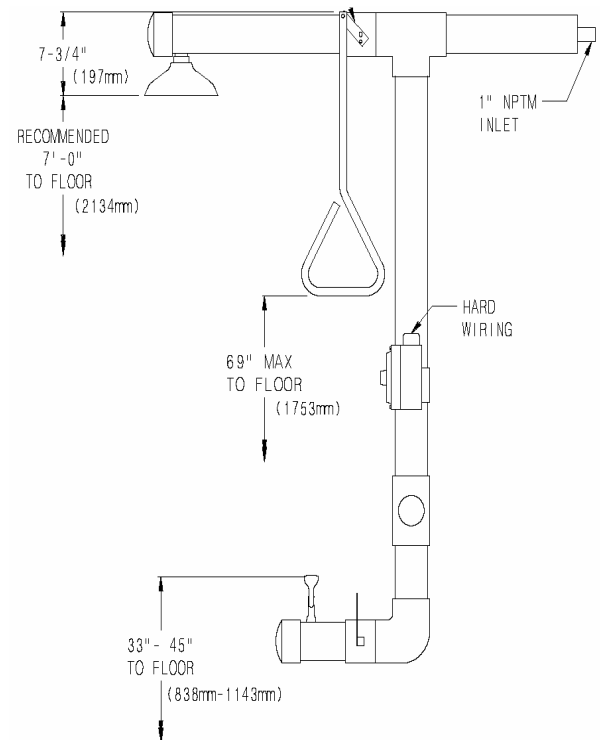

Universal Emergency Sign Included

Compliance: Meets ANSI Z358.1, FM Certified

OPTIONS

- Freeze Protection Valve (FPV)
- Scald Protection Valve (SPV)
- Flow Switch (FLW)
- Hand Held Spray (HTDH)
- Top Supply (TS)

Job Name _____
Location _____
Architect/Engineer _____
Sales Representative _____
Wholesaler _____
Date _____ Model # _____